

USER MANUAL

Thank you for purchasing this 2-Directional Boundary Microphone. Please make sure to read this User Manual before use.

SAFETY PRECAUTIONS

CAUTION

Misuse of the product may cause injury to the user or cause property damage.

- Do not swing the microphone by pulling the cables of the microphone. Otherwise, the cables may break and cause accident.
- Do not disassemble or alter the unit.
- Do not drop or give a strong force to the microphone or the unit base while connected. Doing so may cause damage to the USB terminal or the unit base.
- Dropping this product may cause injury or unit failure. Place the product in a stable location.

Features

- A compact desktop microphone featuring 2-Directional sound collection, enabled by the software technology developed by NTT Computer and Data Science Laboratories.
- By switching the directionality, it is possible to collect voice according to various situations.
- High-performance noise-cancelling ability.
- The collected sound sources can be transmitted to an external device, eg. a recording system, computer, and tablet*1, via a USB cable or an analog cable (stereo mini plug cable).
*1: This product does not come with any external devices. Please refer to the specifications of each applicable external device.
- As the power is supplied via USB bus power, a personal computer can supply power to the product as well.

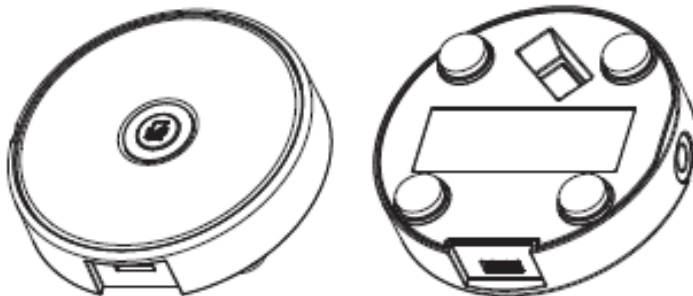

Part Names

● Microphone

DIP Switches

Switch functions of the product.

Red LED (power check)

Flashes when power is supplied.

Mute Button

When pressed and held, blue LEDs flash, enabling the mute function.

USB-C Jack

Stereo Jack

For $\phi 3.5$ Stereo Mini Plug

Blue LED

Illuminates or flashes when sound is detected or settings are changed.

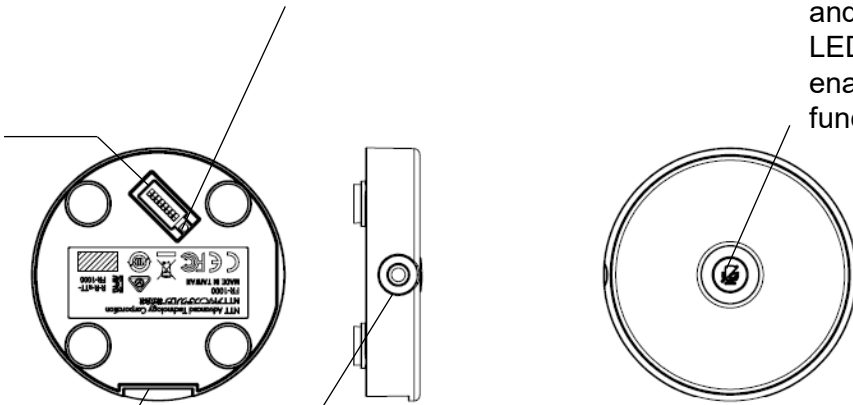

● $\phi 3.5$ Stereo Mini Plug Cable

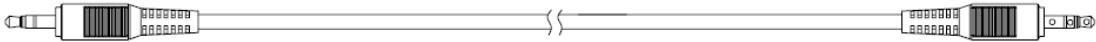

● USB (A-C) Cable

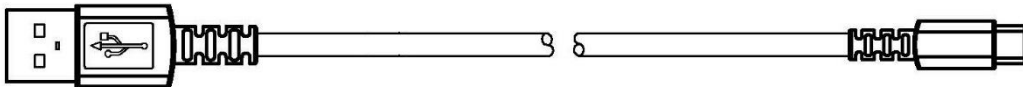

Technical Data

Model: FR-1200

- Directionality Characteristic: 2-directional (stereo)
- Frequency Characteristic: 60 to 7,000Hz
- Current Consumption: 100mA
- Power: USB bus power (DC5V)
- External Dimensions: H14.5 mm \times ϕ 64.7 mm
- Weight: Approximately 61 g (excluding cables)
- Supported OS: Potentially any OS that supports USB Audio Class 1.0 (tested on Windows 11).
- Accessories: a $\phi 3.5$ Stereo Mini Plug cable (approx. 1m) and a USB (A-C) cable (approx. 1 m)

(Specifications may be changed without notice for improvement.)

Mode Switching

The DIP switches on the backside of the unit let you set functions and switch between modes.

	1	2	3	4	5	6	7	8
Function	Sets direction.		Sets width of direction	Sets the blue LEDs	Sets sound processing	Sets analog output	Sets USB output	Sets mute function
ON	*See table below.		Narrow width of Directivity	Enabled (LEDs where sound is detected illuminate.)	Enabled	Mic output	Loud volume	Enabled
OFF			Broad width of Directivity	Disabled	Disabled	Line output	Small volume	Disabled

★Functional Details of DIP Switch Positions 1 and 2

Mode	1	2	Directionality
A	ON	ON	180 degrees: Collects sound from two directions (<u>± 90 degrees</u>).
B	ON	OFF	90 degrees: Collects sound from <u>two directions</u> (<u>± 45 degrees</u>).
C	OFF	ON	270 degrees: Collects sound from <u>two directions</u> (<u>± 135 degrees</u>).
D	OFF	OFF	Single direction: Collects sound from <u>a single direction</u> (<u>$+90$ degrees</u>). (The same content is sent to both the right and left channels.)

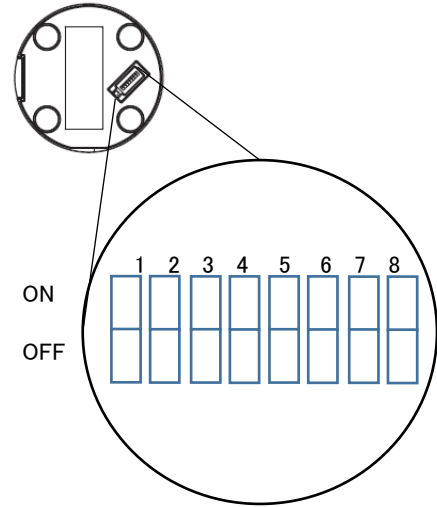

Setting the Directionality

Directionality may be switched between the following four modes.

(A) 180-degree mode: Collects sound from two directions (± 90 degrees).

(B) 90-degree mode: Collects sound from two directions (± 45 degrees).

(C) 270-degree mode: Collects sound from two directions (± 135 degrees).

(D) Single direction mode: Collects sound from a single direction ($+90$ degrees). (The same content is sent to both the right and left channels.)

Collects sound from
-90 degree direction

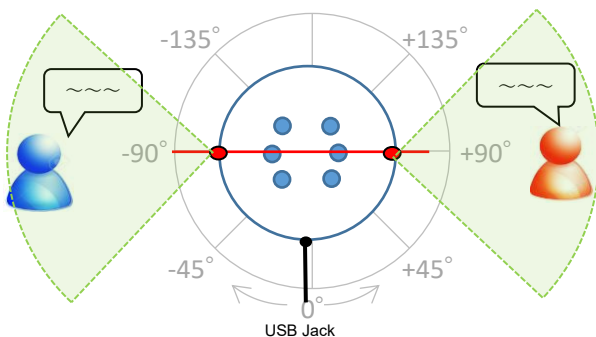

(A) 180-Degree Mode

Collects sound from
+90 degree direction

Collects sound from
-45 degree direction

Collects sound from
+45 degree direction

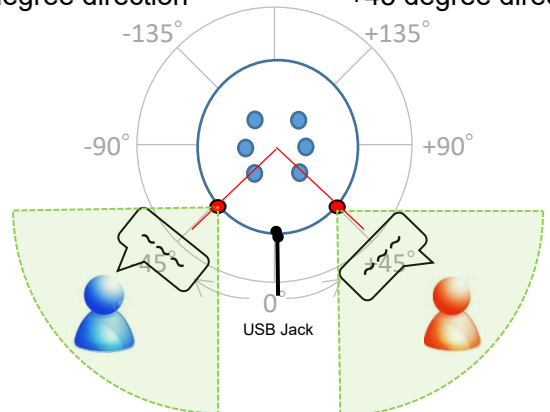

(B) 90-Degree Mode

Collects sound from
-135 degree direction

Collects sound from
+135 degree direction

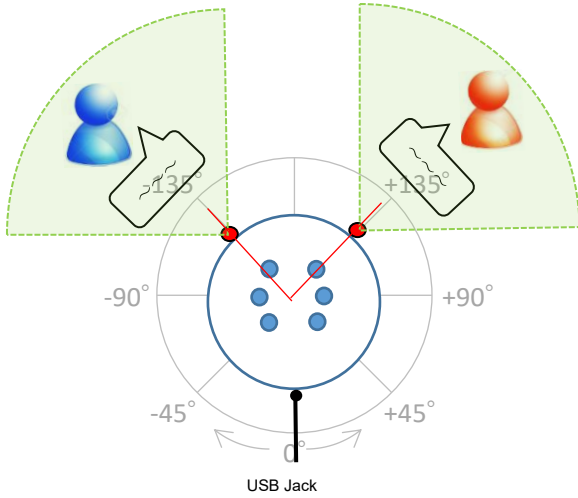

(C) 270-Degree Mode

Collects sound from
+90 degree direction

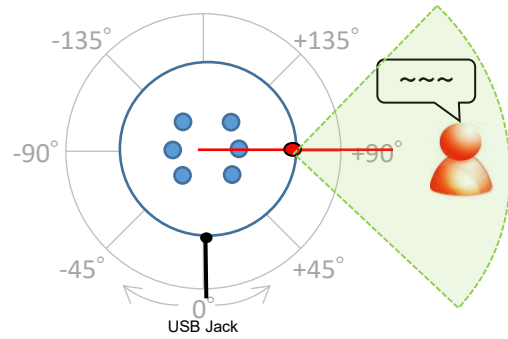

(D) Single Direction Mode

Setting the Width of Directivity

The width of the direction can be set and switched between the following eight modes.

- (i)Narrow width of Directivity & 180-degree Direction
- (ii)Broad width of Directivity & 180-degree Direction
- (iii)Narrow width of Directivity & 90-degree Direction
- (iv)Broad width of Directivity & 90-degree Direction
- (v)Narrow width of Directivity & 270-degree Direction
- (vi)Broad width of Directivity & 270-degree Direction
- (vii)Narrow width of Directivity & Single Direction
- (viii)Broad width of Directivity & Single Direction

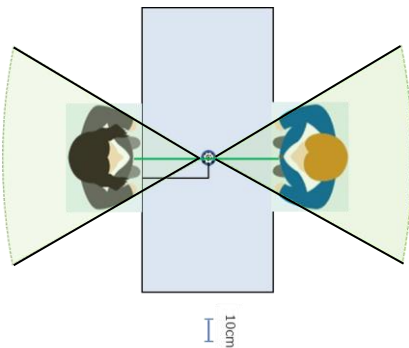

(i)Narrow width of Directivity & 180-degree Direction

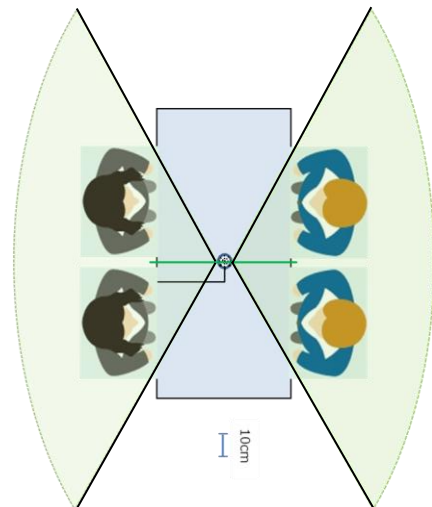

(ii)Broad width of Directivity & 180-degree Direction

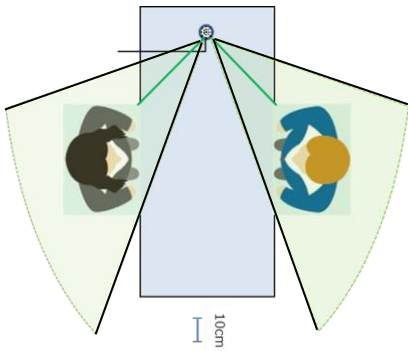

(iii) Narrow width of Directivity & 90-degree Direction

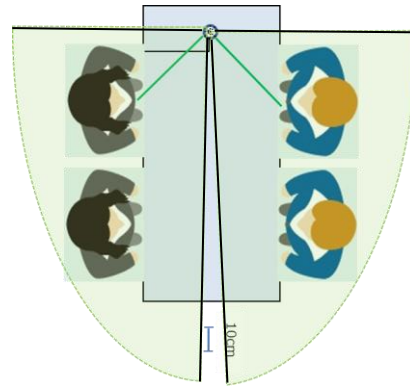

(iv) Broad width of Directivity & 90-degree Direction

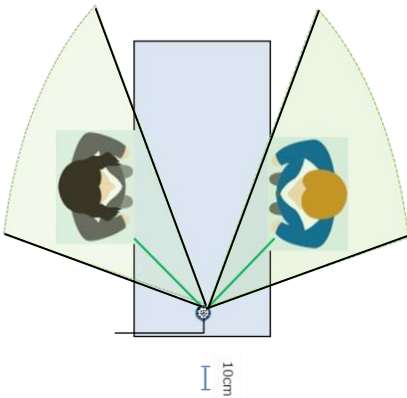

(v) Narrow width of Directivity & 270-degree Direction

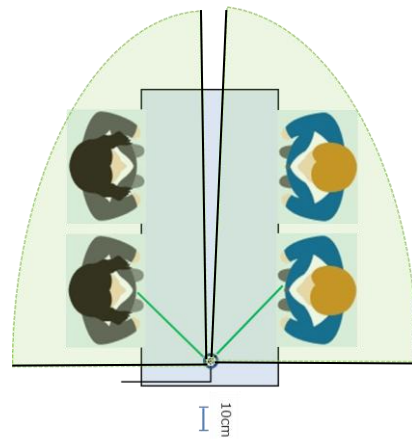

(vi) Broad width of Directivity & 270-degree Direction

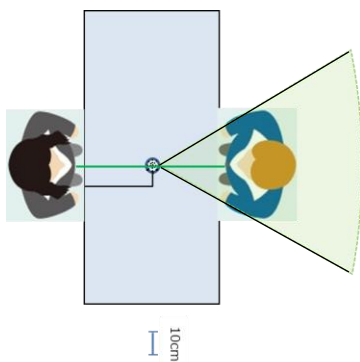

(vii) Narrow width of Directivity & Single Direction

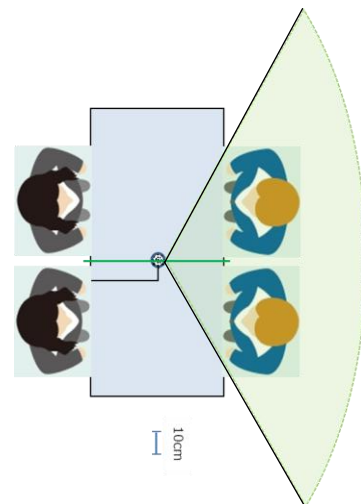

(viii) Broad width of Directivity & Single Direction

Setting the Blue LEDs

Enabling this setting allows LEDs to illuminate when a sound is detected, and to flash to indicate a mode change while the DIP is switched.

LED illuminates when sound is detected

When the unit detects a sound, the LED located in the direction of the sound source illuminates.

Mode Indication

The following table shows the illumination/flashing patterns of the blue LEDs.

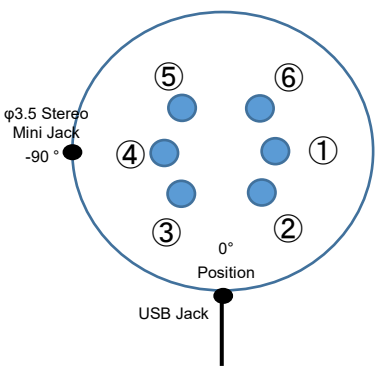

	180 Degrees		90 Degrees		270 Degrees		Single Direction	
	Narrow-width	Broad-width	Narrow-width	Broad-width	Narrow-width	Broad-width	Narrow-width	Broad-width
When DIP Switched	1 & 4 flash quickly	1 & 4 flash slowly	2 & 3 flash quickly	2 & 3 flash slowly	5 & 6 flash quickly	5 & 6 flash slowly	1 flashes quickly	1 flashes slowly
Normal	Off. Or illuminates when sound is detected (for enabled direction only)							
Mute On	All LEDs flash.							
Error	No. 1, 3, 5, 2, 4, and 6 LEDs flash alternately.							

Setting Sound Processing

This setting switches between enabling and disabling the sound processing function.

Enabled: Directionality and noise cancelling functions are enabled.

Disabled: Directionality and noise cancelling functions are disabled, and you can use the microphone as a normal microphone(MONO) to collect sound from all directions.

Setting Analog Output

This setting switches the unit to the analog output mode.

Mic output: Use this to connect to the mic input.

Line output: Use this to connect to the line input.

Setting USB Output

This setting adjusts the volume of USB output.

Choose the appropriate volume that corresponds to the setting of the connected device.

Setting the Mute Function

This setting switches between enabling and disabling the mute function.

Enabled: The mute function is on.

Disabled: The mute function is off.

How to Connect

This product can be connected via a USB cable or a stereo mini plug cable. Check the specification of the mic input of the device to which the product is connected.

Using a USB Cable

- (1) Place the unit on a horizontal surface that is not subject to vibration and make sure there is no barrier between the microphone and the source of voice.
- (2) Insert the USB plug into the USB port of the applicable device.

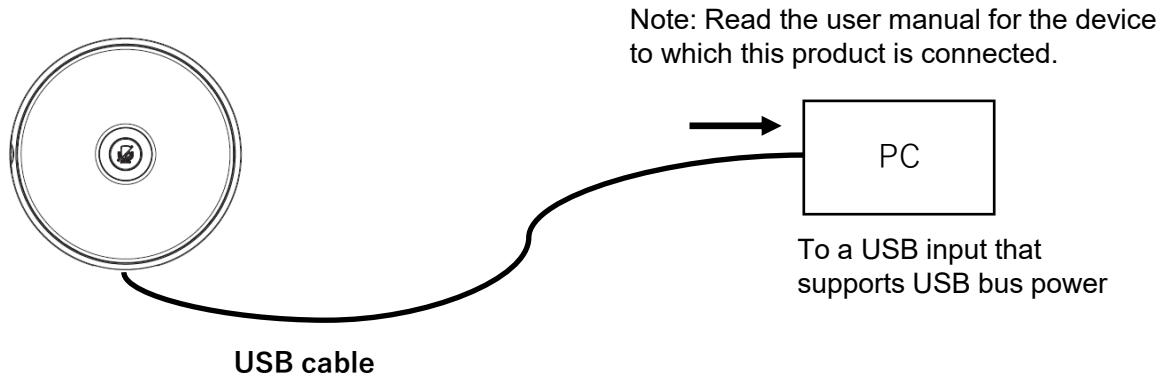

Using a Stereo Cable

- (1) Place the unit on a horizontal surface that is not subject to vibration and make sure there is no barrier between the microphone and the source of voice.
- (2) Insert the stereo plug into the mic input / line input of the applicable device.
- (3) Connect the USB cable to device that can supply power. Use a power adapter (not included) to connect to a wall electrical outlet.

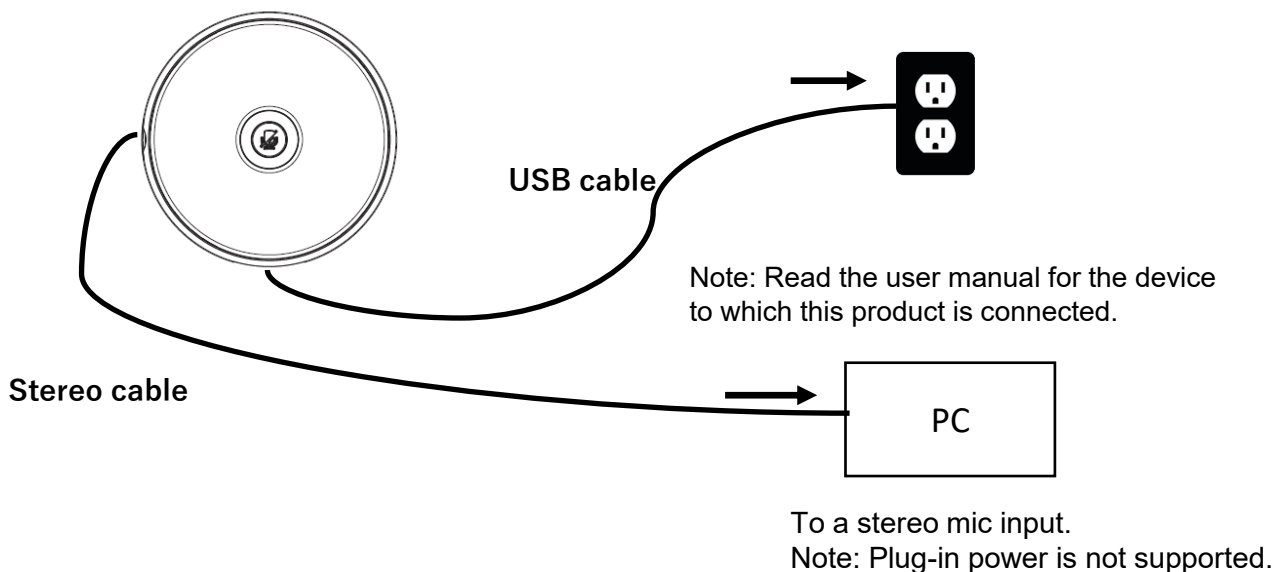

Verification of Connection

Verifying Computer Settings (Windows 10)

Follow the steps below to verify the computer settings. The normal Windows 10 screen is used here. The screen display may differ depending on your operating system.

- (1) Click <Start> and then <Settings>.
- (2) Click <System>.
- (3) Click <Sound>.
- (4) Verify that Echo-Cancelling Speakerphone is selected as input device.

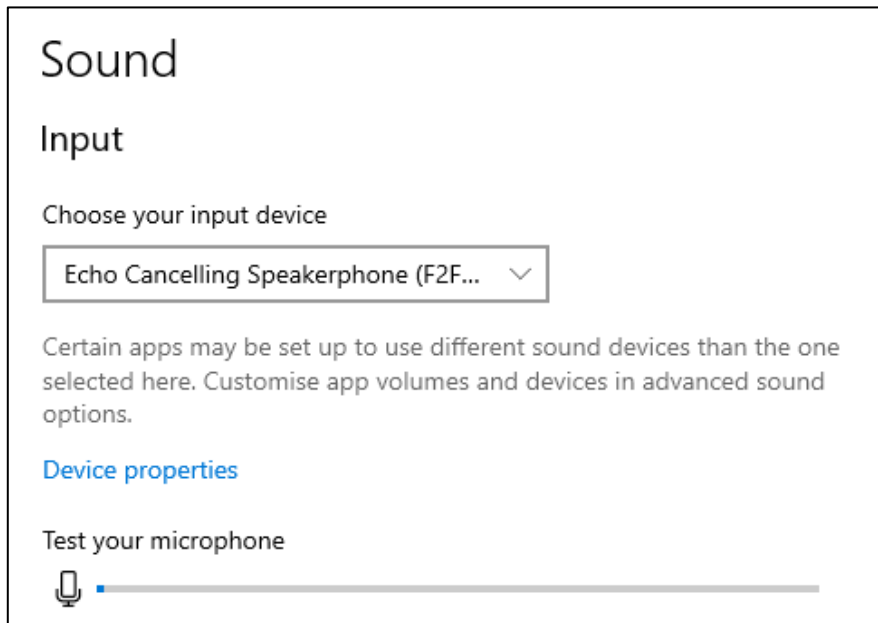

Note: If the microphone is not recognized, please disconnect the microphone and re-connect it.

Recommended setup position

Range of sound collection in the vertical direction

Elevation angle between speaker's mouth and FR-1200 is less than thirty-degree. Make sure that the speaker's mouth remains within the sound collection range.

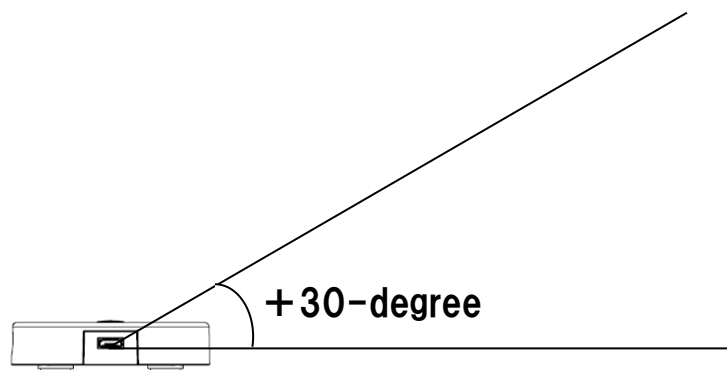

e.g. Installation in a straight line

For installation in a straight line, refer to the diagram below for optimal performances.

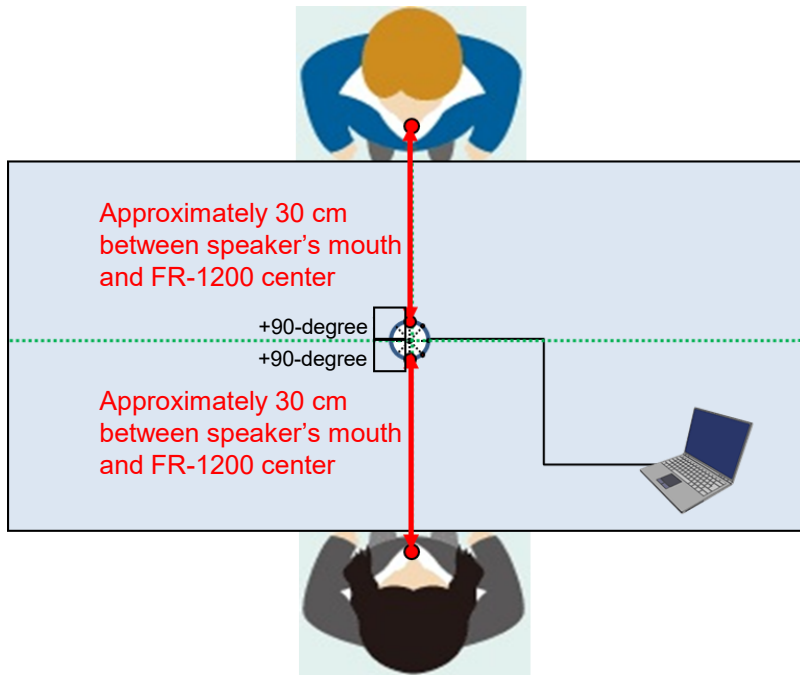

e.g. Diagonal installation.

For installation in a diagonal line, refer to the diagram below for optimal performances.

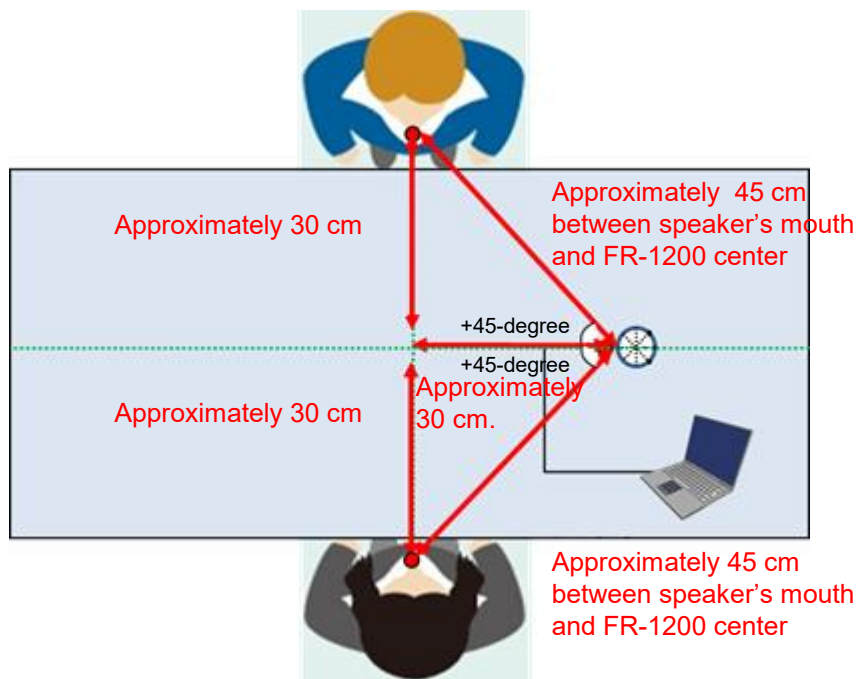

Precautions for Use



Caution

Misuse may result in malfunction.

- Before use, ensure to read the user manuals for the devices to which this product is connected.
- We are not responsible whatsoever should any data in your computer be lost while this product is connected to it.
- Do not give the product a strong shock.
- Do not expose this product to direct sunlight, or place it near a heating device, or in a hot, humid, or dusty location. Do not expose this product to water.
- This product may discolor due to friction after a long period of use.
- To connect/disconnect the cables, insert/pull it out by inserting/pulling the plug, not the cables. Otherwise the cables may break and cause accident.
- Do not place any object on the microphone.
- Do not place anything that blocks or reflects the sound within 1 m of the product.

Notes on export control



Caution

- When re-exporting a product, the customer or end-user must follow the necessary procedures stipulated in the export-related laws of the country to which the customer or end-consumer belongs.

Supplier's Declaration of Conformity

FCC Caution

Changes or modifications not expressly approved by the party responsible for compliance could void the user's authority to operate the equipment.

FCC Class B Statement

This equipment has been tested and found to comply with the limits for a Class B digital device, pursuant to Part 15 of the FCC Rules. These limits are designed to provide reasonable protection against harmful interference in a residential installation. This equipment generates, uses and can radiate radio frequency energy and, if not installed and used in accordance with the instructions, may cause harmful interference to radio communications. However, there is no guarantee that interference will not occur in a particular installation. If this equipment does cause harmful interference to radio or television reception, which can be determined by turning the equipment off and on, the user is encouraged to try to correct the interference by one or more of the following measures:

- Reorient or relocate the receiving antenna.
- Increase the separation between the equipment and receiver.
- Connect the equipment into an outlet on a circuit different from that to which the receiver is connected.
- Consult the dealer or an experienced radio/TV technician for help.

Certifications



After-Sales Service

Should a failure occur while the use is using the product in accordance with the User Manual and clauses regarding connection and precautions, we will provide a free repair based on the terms and conditions of the warranty.

Please contact the dealer from whom you purchased this product for questions regarding the product or consultation regarding a failure and repair.

NTT ADVANCED TECHNOLOGY CORPORATION

Tokyo Opera City Tower, 3-20-2, Nishi-shinjuku, Shinjuku-ku, Tokyo, 163-1436, Japan